



IceFlow™ Containment Product Guide

IceFlow™ Hot/Cold aisle Containment Products

- Cold Aisle Doors – Double/Single/Hinged or Softwall
- Walls – Rigid, SoftWall, Stand Alone
- Ceilings – Heat Activated Drop Away
- Hot/Cold Directional/Blanking Door

IceFlow™ Blanking Products

- IceFlow Blanking Foam
- IceFlow Grommets
- IceFlow Blanking Panels
- IceFlow Baffle Wall
- Raised floor panel lifters



IceFlow™ RIGID DOORS

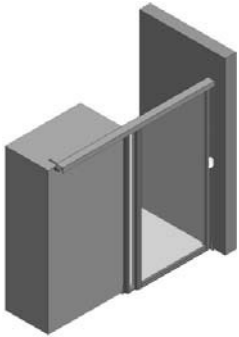
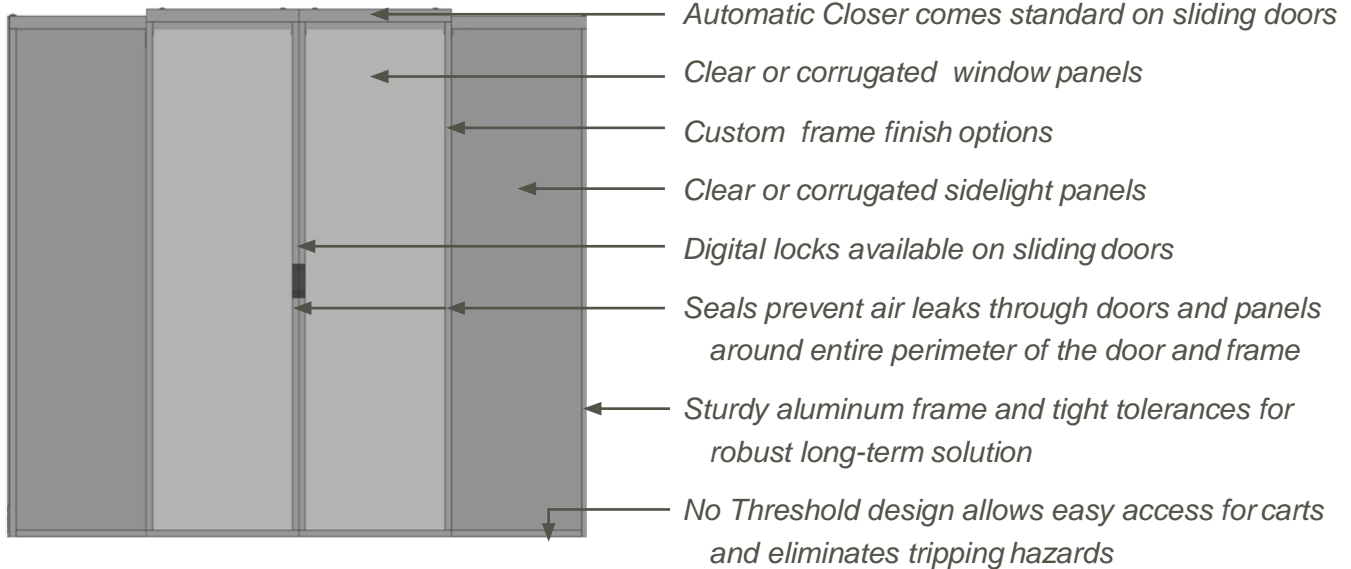

Custom built to fit any type or size of opening

- Doors can be installed between two cabinets or between a cabinet and a wall
- Each door is built custom to the height and width of the opening
- Doors can be customized for uneven cabinets and narrow aisles
- Mounts to cabinet, floor, or freestanding



Custom Finish Options

- Black or clear anodized
- Custom powder coating colors

www.triadairflow.com or 720-530-8699

**This copy is provided on a Restricted Basis and is not to be used in any way Detrimental to the Interests of Triad.*



IceFlow™ Double Sliding Door

- Automatic Door Closer for a smooth soft close (comes standard)
- Sturdy aluminum frame
- Clear or corrugated light panels
- Door catch holds door open
- Custom finish options available
- NFPA compliant

IceFlow™ Pivot Dual Swinging Door

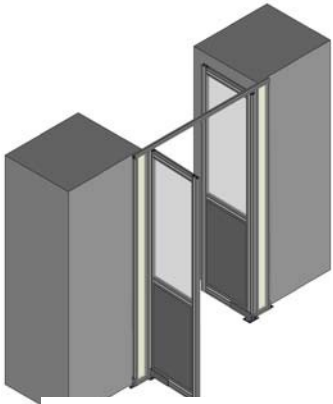

- Pivot hinges allow doors to swing 90 degrees in either direction
- Solid metal bottom panels to protect against carts
- Sturdy aluminum frame
- Clear or corrugated door and side panels
- Custom finish options available
- NFPA compliant

IceFlow™ Single Sliding Door

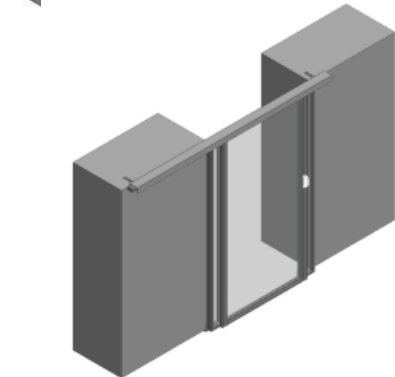

- Automatic Door Closer (comes standard)
- Sturdy aluminum frame
- Clear or corrugated light panels
- Door catch holds door open
- Can be built cabinet to wall
- Custom finish options available
- NFPA compliant

IceFlow™ Swinging Door



- Hinged door opens 90 degrees in either direction
- Custom finish options available
- Clear or corrugated light panels
- Sturdy aluminum frame
- Can be built cabinet to wall
- NFPA compliant

www.triadairflow.com or 720-530-8699

**This copy is provided on a Restricted Basis and is not to be used in any way Detrimental to the Interests of Triad.*



CONTAINMENT

IceFlow™ RIGID CONTAINMENT

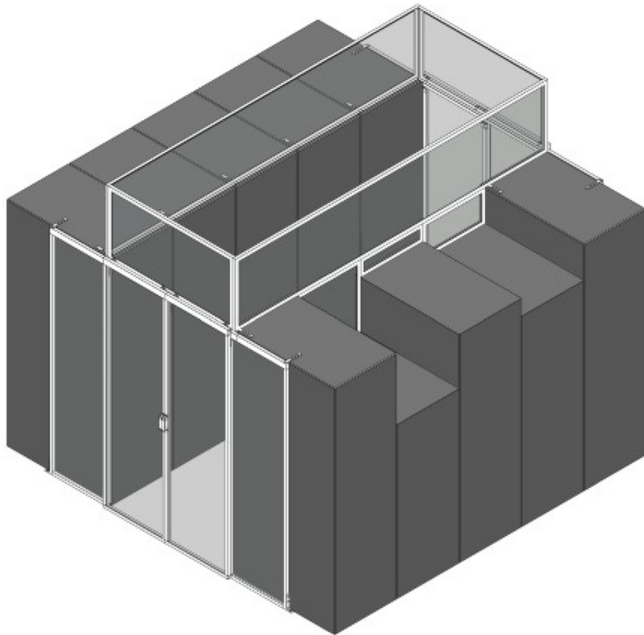

Rigid Containment is built with an aluminum frame and either clear or corrugated panels. Used in both hot and cold aisle containment, the panels can be made to fit the gaps created from inconsistent cabinet heights, obstructions, and spaces between cabinets and ceiling. The panels are shipped assembled and with hardware for easy installation.

IceFlow™ Melt-Away Ceiling

Melt-Away Ceiling panels are made with an aluminum frame and clear polyvinyl melt away inserts that shrink and drop to the floor prior to fire suppression being activated. Frames are built 2 ft in width, and can be customized in length to cover most aisle openings.

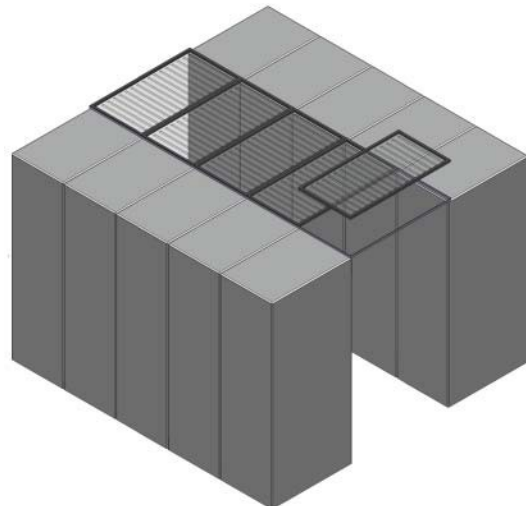

IceFlow™ Rigid Walls (attached or stand-alone)

Rigid walls are the ideal containment solution to fill gaps between cabinets, cabinet to walls, or spaces above cabinets. Rigid walls can be made to fit any size opening, and can be built with clear or corrugated panels.

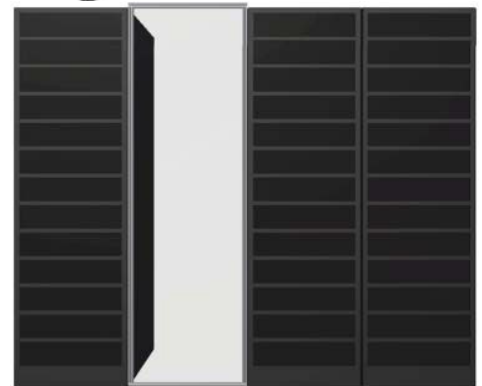

www.triadairflow.com or 720-530-8699

**This copy is provided on a Restricted Basis and is not to be used in any way Detrimental to the Interests of Triad.*



IceFlow™ SOFT WALL CONTAINMENT (attached or stand-alone)

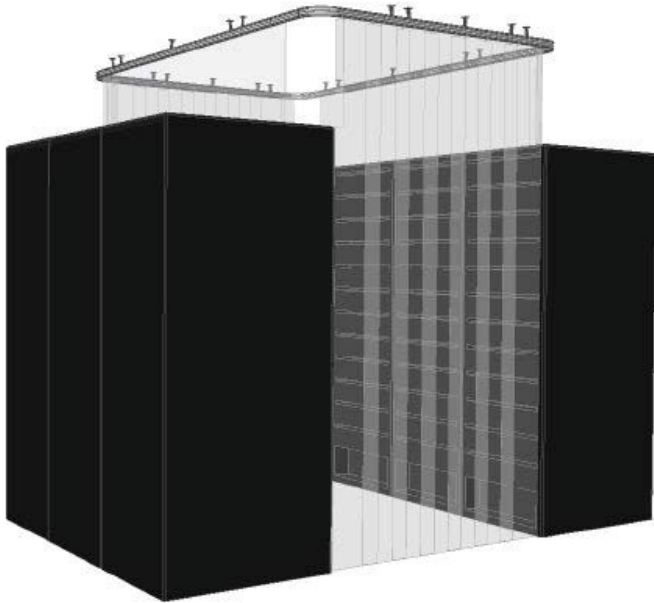

Soft wall containment can be a lower cost solution for isolating the air in hot and cold aisles.

Soft wall containment is custom made to fit any opening and aisle length. The containment comes standard with clear soft vinyl, but can be upgraded to a silicone coated fabric that meets NFPA standards.

90 degree track ensures the curtains are sealed tight around corners.

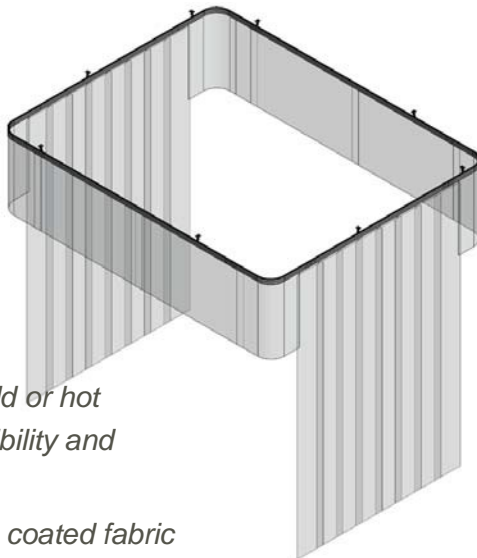

Clear Vinyl seals cold or hot air while allowing visibility and light into aisles.

- A white Silicone coated fabric that meets the NFPA standards is also available.

Fusible Links



Heat activated fusible links attach to ceiling and release curtains for unobstructed fire suppression.



An optional electronic fusible link can connect to the fire suppression system, releasing curtains from an electronic signal or mechanically from heat.

www.triadairflow.com or 720-530-8699

**This copy is provided on a Restricted Basis and is not to be use in any way Detrimental to the Interests of Triad.*



CONTAINMENT

IceFlow™ MECHANICAL DROP AWAY CEILING

Mechanical Drop Away Ceiling is a new product in cold aisle containment. The mechanical system is customizable to drop the ceiling panels upon a signal from the fire suppression system and can include any early warning detection system. It will not compromise egress per NFPA 101 life safety codes. Redundancy is built in to melt the panels if no signal is received from the fire suppression system.

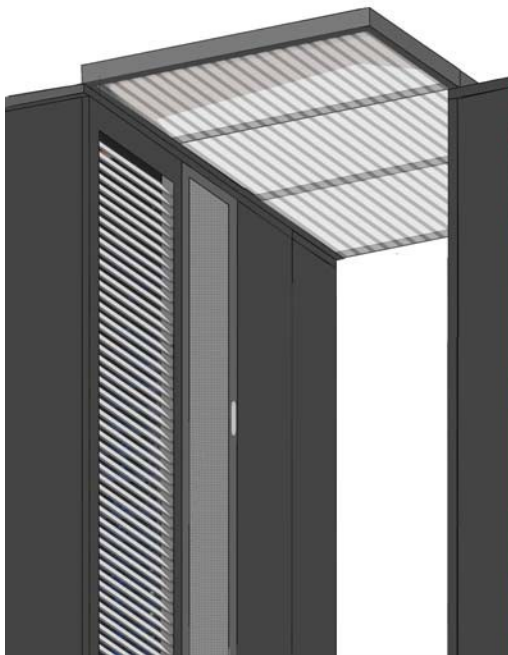
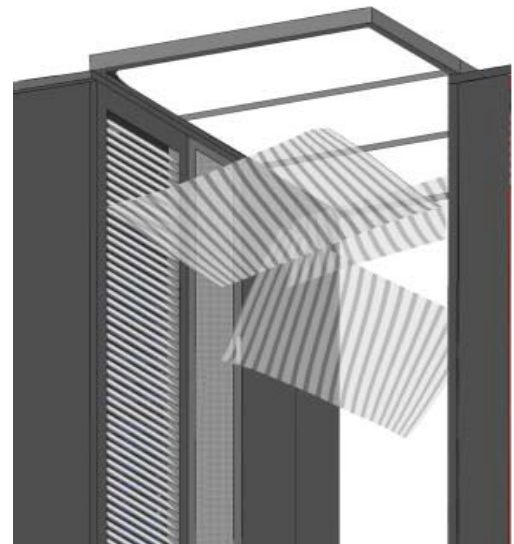

Figure 1 is showing the ceiling panels in place in a normal position.

Figure 2 demonstrates the panels falling harmlessly to the floor when released by a signal from the fire suppression system.



The system is easily reset and the panels put back in place.

- Rigid Aluminum Frame
- 15 mil Clear Polyvinyl Panels
- ASTM E84 Compliant
- UL listed for use in fire suppression systems

www.triadairflow.com or 720-530-8699

**This copy is provided on a Restricted Basis and is not to be use in any way Detrimental to the Interests of Triad.*



IceFlow™ Directional/Blanking Door

This innovative retro-fit design increases server airflow density while remedying data center and server farm hot spot challenges.

Creates immediate improved airflow in both Hot and Cold aisle.

Chimney flow effect creates pull through from Cold aisle and superior heat return from Hot aisle.

No fans, no chimney's just Passive fluid flow.

3 step, 5 minute installation on most all existing racks.

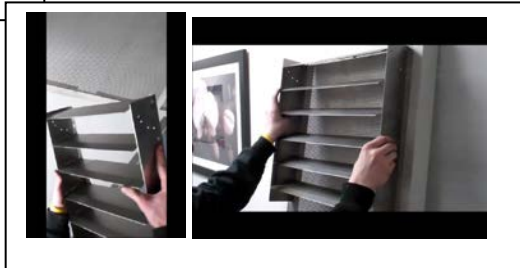
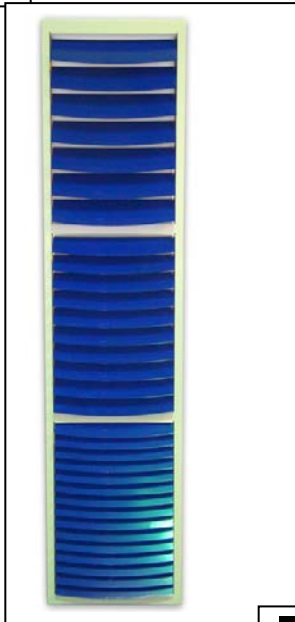



IceFlow™ Accessories

- Blanking Products
- Baffle Products
- Grommet Products
- Panel Lifters
- Floor Outlet Boxes

Grommet/Trim/Diffuser Products



Panel Lifter Products

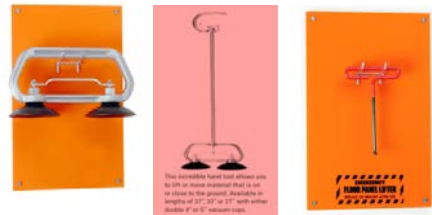

IceFlow™ Blanking Foam Products



*Blanking Foam
Available in Colors
Custom sizing
1" x 1" x 1" to 4" x 36" x 85"
Fire Rated
Chemical Rated Available*